

BANDO POWER ACE

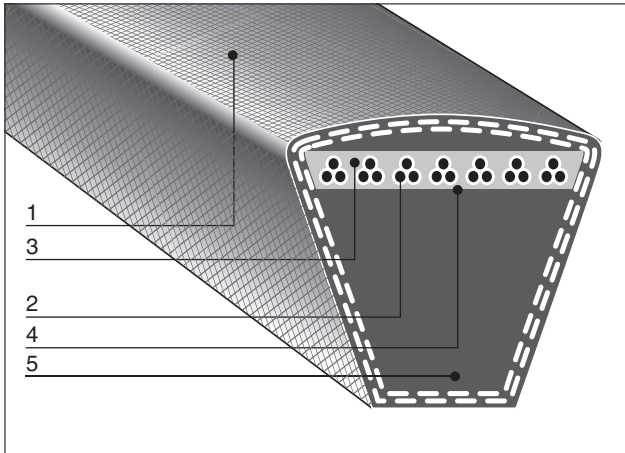

Construction

- 1: Rubber impregnated canvas
- 2: Polyester tensile members
- 3: Chloroprene insulation rubber
- 4: Special lateral reinforcing cord
- 5: Chloroprene compression rubber

Features

- High horsepower rating
Requires about 1/3 of the space needed by traditional Multiple V Belt drive.
- Long life
- High heat and oil resistance
- Length stability. A matched set of Bando Power Ace for multiple belt drives retains superior uniformity under tension. A Bando matched set remains perfectly matched even after long periods of storage.
- Power Ace raised crookedness nature by making texture of canvas into 120 degrees instead of 90 degrees of conventional V-belt.

Power Ace
Outer Jacket.



Conventional V-belt
Outer Jacket.



Dimensions

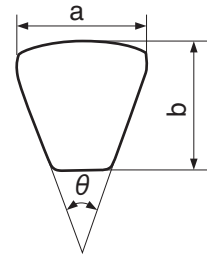

Type	Top width a	Thickness b	Angle θ
3V	9.5mm (0.38")	8.0mm (0.32")	40°
5V	16.0mm (0.62")	13.5mm (0.54")	40°
8V	25.5mm (1.0")	23.0mm (0.88")	40°

Size mark

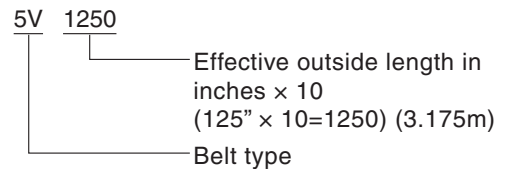

Pulley

Use RMA Engineering Standards recommended pulley groove dimensions, IP-22 (Specifications for Drives Using Narrow Multiple V-BELTS).

BANDO POWER ACE

The superior power transmission capacity of the Bando narrow Power Ace® V-belts allows for drive designs with smaller components reducing machine space and cost. The higher efficiency of the Power Ace® V-belts will also result in decreased operating costs.

Just three types of Bando Power Ace ideally cover all five sections of multiple V-belts. For multiple or single drives, the 3V replaces A, and B sections; the 5V replaces C and D sections; and the 8V replaces D and E sections.

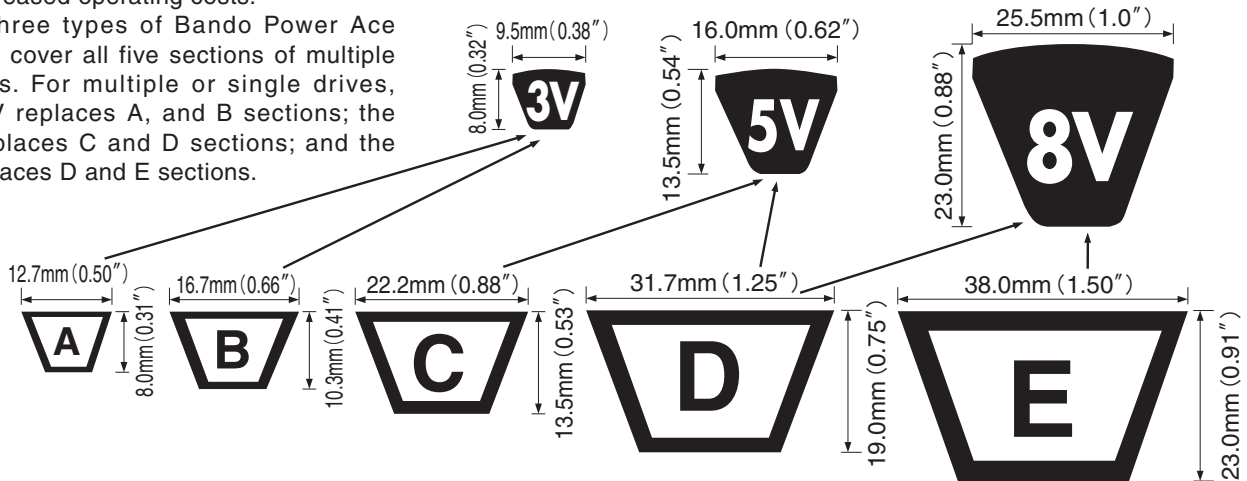

Standard Sizes

※These sizes are in conformity to RMA.

Belt number	Effective outside length		Belt number	Effective outside length		Belt number	Effective outside length	
	mm	inch		mm	inch		mm	inch
3V 250	635	25.0	3V 475	1207	47.5	3V 900	2286	90.0
3V 265	673	26.5	3V 500	1270	50.0	3V 950	2413	95.0
3V 280	711	28.0	3V 530	1346	53.0	3V1000	2540	100.0
3V 300	762	30.0	3V 560	1422	56.0	3V1060	2692	106.0
3V 315	800	31.5	3V 600	1524	60.0	3V1120	2845	112.0
3V 335	851	33.5	3V 630	1600	63.0	3V1180	2997	118.0
3V 355	902	35.5	3V 670	1702	67.0	3V1250	3175	125.0
3V 375	953	37.5	3V 710	1803	71.0	3V1320	3353	132.0
3V 400	1016	40.0	3V 750	1905	75.0	3V1400	3556	140.0
3V 425	1080	42.5	3V 800	2032	80.0			
3V 450	1143	45.0	3V 850	2159	85.0			
5V 500	1270	50.0	5V1000	2540	100.0	5V2000	5080	200.0
5V 530	1346	53.0	5V1060	2692	106.0	5V2120	5385	212.0
5V 560	1422	56.0	5V1120	2845	112.0	5V2240	5690	224.0
5V 600	1524	60.0	5V1180	2997	118.0	5V2360	5994	236.0
5V 630	1600	63.0	5V1250	3175	125.0	5V2500	6350	250.0
5V 670	1702	67.0	5V1320	3353	132.0	5V2650	6731	265.0
5V 710	1803	71.0	5V1400	3556	140.0	5V2800	7112	280.0
5V 750	1905	75.0	5V1500	3810	150.0	5V2800	7620	300.0
5V 800	2032	80.0	5V1600	4064	160.0	5V3000	8001	315.0
5V 850	2159	85.0	5V1700	4318	170.0	5V3150	8509	335.0
5V 900	2286	90.0	5V1800	4572	180.0	5V3550	9017	355.0
5V 950	2413	95.0	5V1900	4826	190.0			
8V1000	2540	100.0	8V1800	4572	180.0	8V3150	8001	315.0
8V1060	2692	106.0	8V1900	4826	190.0	8V3350	8509	335.0
8V1120	2845	112.0	8V2000	5080	200.0	8V3550	9017	355.0
8V1180	2997	118.0	8V2120	5385	212.0	8V3750	9525	375.0
8V1250	3175	125.0	8V2240	5690	224.0	8V4000	10160	400.0
8V1320	3353	132.0	8V2360	5994	236.0	8V4250	10795	425.0
8V1400	3556	140.0	8V2500	6350	250.0	8V4500	11430	450.0
8V1500	3810	150.0	8V2650	6731	265.0	8V4750	12065	475.0
8V1600	4064	160.0	8V2800	7112	280.0	8V5000	12700	500.0
8V1700	4318	170.0	8V3000	7620	300.0	8V5600	14224	560.0