

**ELEMENTOS TENSORES
UNIVERSALES TIPO «TE»**
UNIVERSAL TENSIONERS TYPE «TE»

 **RESATEC AG**

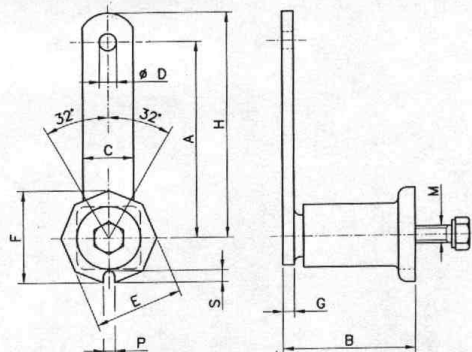

TIPO TYPE	A	B	C	ØD	E	F	G	H	FUERZA MAX. en N TORQUE en N ∠0-32°	M	p	S	PESO WEIGHT Kg.
TE 2	80	52	20	8.5	35	38	5	90	0-90	M6	7	5	1250
TE 3	100	63	25	10.5	46	48	5	112.5	0-140	M8	7	6	1250
TE 4	100	78	30	10.5	56	59	6	115	0-320	M10	7	8	780
TE 5	130	108	50	12.5	72	76	8	155	0-820	M12	10	8	780
TE 6	175	140	60	20.5	93	97	10	205	0-1500	M16	12	8	760
TE 7	220	198	70	20.5	106	112	12	260	0-2400	M20	12	8	760

PIÑONES TENSORES TIPO «KS»
SPROCKETS WHEELS TYPE «KS»

 **RESATEC AG**

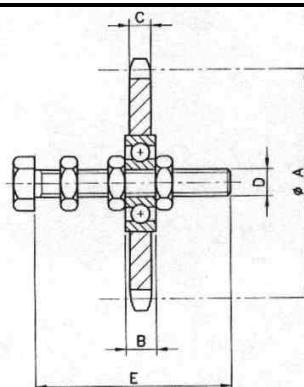

TIPO TYPE	Nº DIENTES	ØA	B	C	D	E	CADENA CHAIN DIN8187	PESO WEIGHT Kg
KS 3/8" x 7/32"	15	45.81	9	5.7	M10	60	ISO-06B	0.15
KS 1/2" x 5/16"	15	61.08	9	7.2	M10	60	ISO-08B	0.20
KS 1/2" x 5/16"	15	61.08	12	7.2	M12	80	ISO-08B	0.23
KS 5/8" x 3/8"	15	76.36	12	9.1	M12	80	ISO-10B	0.37
KS 5/8" x 3/8"	15	76.36	15	9.1	M20	120	ISO-10B	0.40
KS 3/4" x 7/16"	15	91.63	12	11.5	M12	80	ISO-12B	0.60
KS 3/4" x 7/16"	15	91.63	15	11.5	M20	120	ISO-12B	0.90
KS 1" x 17.02"	13	106.14	15	16.2	M20	120	ISO-16B	1.30
KS 1 1/4" x 3/4"	13	132.67	15	18.5	M20	140	ISO-20B	2.05
KS 1 1/2" x 1"	11	135.23	15	24.1	M20	140	ISO-24B	2.40



WEDA TRANSMISIONES S.L.

C./Circunvalación, 45
Tel. 93 719 05 57 - Fax 93 718 24 43
08210 BARBERÀ DEL VALLÈS (Barcelona)
E-mail: rcarner.weda@nexo.es